

AVR-20 ALTERNATOR VOLTAGE REGULATOR



DESCRIPTION

AVR-20 Voltage Regulator is an electronic device which lets the alternator to produce fixed output voltage.

It has open chassis, resin molded design and is intended to be mounted in the alternator's terminal box.

AVR-20 measures the voltage between one of the alternator phases and the neutral point and adjusts the DC voltage applied to the excitation winding until reaching the desired voltage.

The output stage of the device is a Half Wave thyristor output associated with a free wheeling diode.

Basically the unit is compatible with all brushless type alternators. A stability adjustment potentiometer is also provided for this purpose.

The AVR-20 has a special relay-less electronic circuit design. The required minimum residual voltage for build up is 5 V-AC. The unit does not include moving parts; therefore it is able to operate in highly vibrating environments.

The AVR-20 includes a low frequency protection circuit. This feature reduces the output voltage during overload or engine

stop. Therefore the diesel engine is protected from excessive torque generated by high startup currents of large electrical equipments.

Similarly, the diesel engine may be stopped under load without damage.

The easy connection scheme of the device allows fast and easy replacement.

FEATURES

- Half-Wave thyristor output,*
- 0-20 amps. output current,*
- 0-115 volts output voltage,*
- Relay-less circuit design,*
- Low frequency protection,*
- Built in voltage adjustment,*
- Stability adjustment,*
- Remote voltage adjustment feature,*
- Easy connection scheme,*
- Compatible with various types of alternators,*

OPERATION

The device operates on 230-volt phase-to-neutral voltage. The output voltage, as well as the internal supply voltage, is directly picked up from the input sensing voltage. The device needs 5 V-AC for startup.

The half wave thyristor output voltage is 115 volts maximum.

During operation, the device continuously monitors the input voltage and increases/decreases the excitation voltage in order to maintain the input voltage to a constant value.

The AVR-20 keeps the alternator voltage change in minimum limits in case of a load change, and helps to reach the required voltage value quickly.

The regulation is P-I type, the proportional reaction is fast and the slow acting integral reaction helps the unit to recover the precise set voltage.

The stability potentiometer adjusts the reaction speed of the device. This helps the unit to comply with a large variety of alternators.

The AVR-20 is able to produce up to 20 amps continuous current output.

The alternator voltage may be adjusted via the built in potentiometer. Also external voltage adjustment feature is provided, in this case the external potentiometer value shall be 1 kilo-ohms.

The low frequency protection circuit shuts off the excitation voltage in order to prevent damage during engine stopping under load. The factory set value for the protection is 45Hz.

The alternator EXCITATION terminals shall not be connected to any point but the unit. The NEUTRAL and EXCITATION (+) points are internally connected.

INPUTS AND OUTPUTS

PHASE-R: Alternator phase input.

NEUTRAL: Alternator neutral input, internally connected to the Excitation(+) terminal.

EXCITATION (+): Excitation winding (+) terminal, internally connected to the Neutral terminal.

EXCITATION (-): Excitation winding (-) terminal

TECHNICAL SPECIFICATIONS

Phases: single phase.

Voltage Adjustment Range: 210-250 Volts min
Frequency: 50/60Hz.

Frequency Protection Adj. Range: 40-50Hz

Output Voltage: 0-115 volts-DC at 230volts

Output Current: 20A continuous,

Residual Voltage For Build Up: 5 volts minimum
Regulation: +/- 2% typical.

Power Output Stage: Half Wave thyristor.

Internal Fusing: 10A (fast acting fuse)

Operating temp.: -10°C (14°F) to 60 °C (140°F).

Storage temp.: -20°C (-4°F) to 80 °C (176°F).

Maximum humidity: 95% non-condensing.

Dimensions: 125x68x35mm (L x W x H)

Fixing centers: 115mm, 2xM6

Weight: 280grams

CONNECTION DIAGRAM

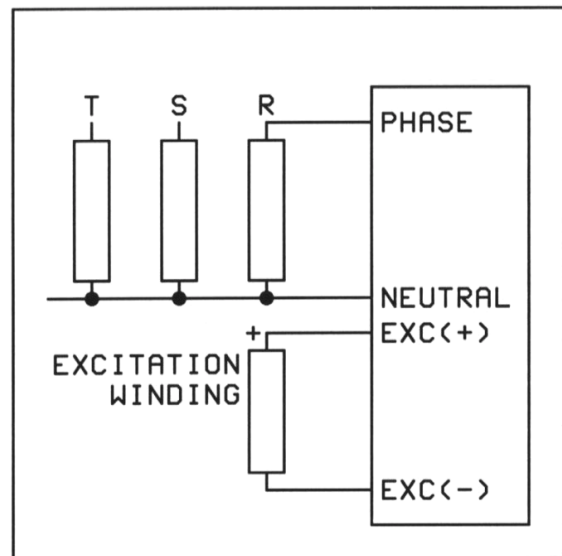

Biuro: biuro@agregaty-serwis.pl

tel +48 61 666 12 16

tel kom. +48 605 836 935

fax +48 61 666 12 25

Serwis: serwis@agregaty-serwis.pl

tel +48 61 666 12 19

tel kom. +48 605 723 006